

**Mesa**vent.

**COLMAN**  
*Air Distribution*

ENGINEERED AIR PRODUCTS

**SWIRL DIFFUSERS**  
**DWT SERIES**



**DWT**  
**SERIES**

# DISTRIBUTION PATTERNS & FIXING OPTIONS

## Application

The DWT Series of swirl diffusers have been designed for the supply of cooled or warmed air to a wide range of commercial applications. A high level of induction is achieved allowing supplied air to mix more thoroughly with room air, closer to the diffuser.

By adjusting the setting of individual radial nozzles different distribution patterns can be created.

A matching extract version is also available with nozzle inserts.

## Description

The diffuser comprises a circular array of black steel supply nozzles fitted within a square steel panel. Nominal size is determined by the number of nozzles and overall face size of the diffuser.

The DWT Series swirl diffusers are available in six standard sizes and four standard styles which will integrate with most types of ceiling systems.

Special styles are available on request.

All swirl diffusers can be supplied with matching side or top entry plenum boxes, with or without mono blade dampers.

## Fixing

The DWT Series diffuser is suitable for mounting at heights of between 2.5m and 4m from floor level. The diffuser plate is fastened to the plenum by a central fixing screw. The side or top entry plenum is to be fixed via drop rods or wires to suitable structural support.

## Finish

The diffuser panel is supplied powder coated white (RAL 9010) matt as standard. Other RAL colours are available on request.

## Distribution Pattern Adjustment Options

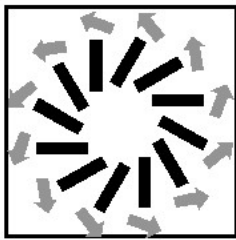

External swirl pattern  
(Code O)

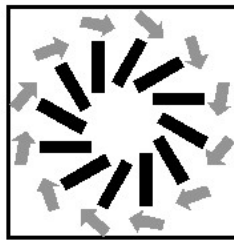

Internal swirl pattern  
(Code S)

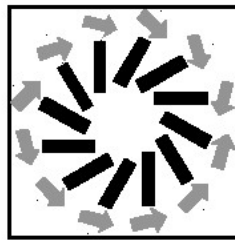

One way pattern  
(Code D)

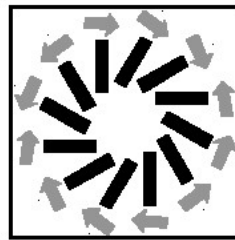

Two way pattern  
(Code C)

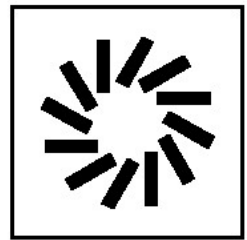

Without nozzles for  
extract (Code X)

## Alternative Ceiling Fixings

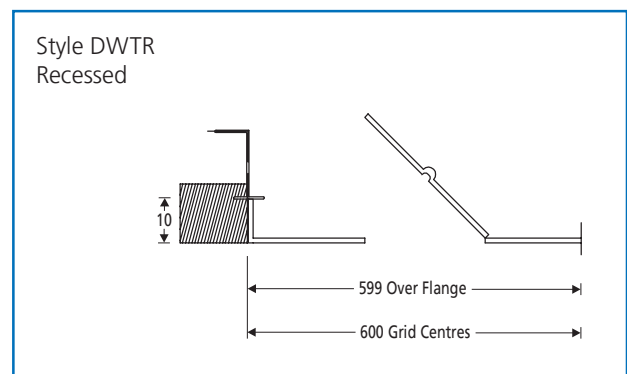
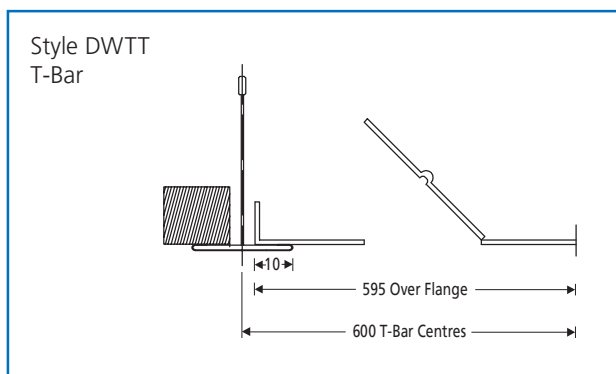
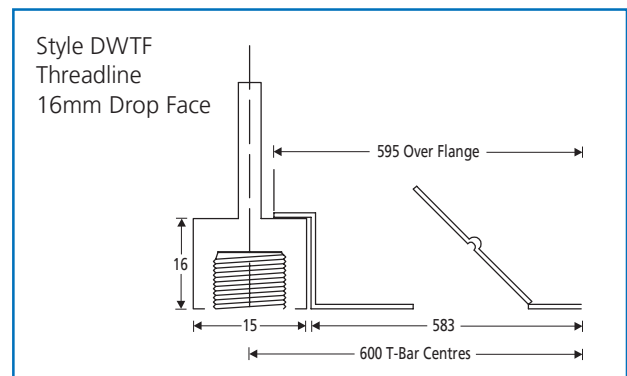
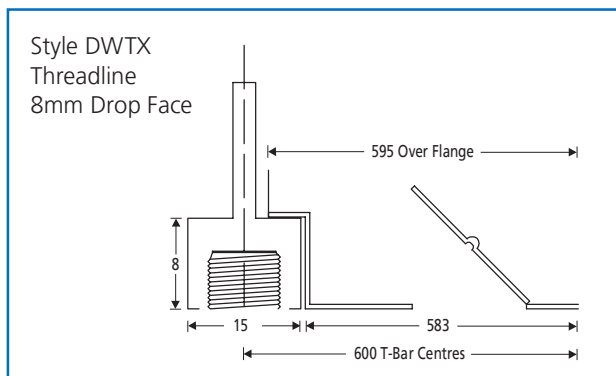

# DIMENSIONS, OPTIONS & ORDER CODES

## Diffuser Dimensions

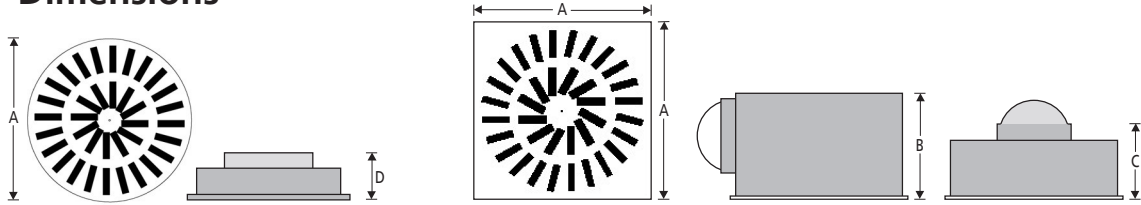

Nominal Size Code	Number of Nozzles	Calculated Free Area (m <sup>2</sup> )	A Overall Panel Size (mm)	A Diameter (mm)	Plenum Size (L & W) (mm)	B Side Entry Plenum Height (mm)	C Top Entry Plenum Height (mm)	D Side Entry Plenum Height (mm)
0930	9	0.0105	294 × 294	300	265 × 265	230	225	75
0940	9	0.0105	394 × 394	400	265 × 265	230	225	75
0950	9	0.0105	494 × 494	500	265 × 265	230	225	75
0960	9	0.0105	594 × 594	600	265 × 265	230	225	75
1240	12	0.014	394 × 394	400	355 × 355	305	225	75
1250	12	0.014	494 × 494	500	355 × 355	305	225	75
1260	12	0.014	594 × 594	600	355 × 355	305	225	75
1640	16	0.0185	394 × 394	400	355 × 355	305	225	75
1650	16	0.0185	494 × 494	500	355 × 355	305	225	75
1660	16	0.0185	594 × 594	600	355 × 355	305	225	75
2050	20	0.0233	494 × 494	500	355 × 355	305	225	75
2060	20	0.0233	594 × 594	600	355 × 355	305	225	75
2450	24	0.0278	494 × 494	500	395 × 395	305	225	75
2460	24	0.0278	594 × 594	600	395 × 395	305	225	75
3660	36	0.04	594 × 594	600	555 × 555	355*	225	75
4860	48	0.05	594 × 594	600	555 × 555	420*	225	75

\*Height will be greater when spigot is 315 diameter or larger.

## Options and Diffuser Order Codes

1. SERIES	2. STYLE	3. CORE	4. ACCESSORIES	5. ARRANGEMENT	6. FIXING	7. FINISH
<b>D</b>	<b>W</b> Swirl <b>1</b> Special	<b>T</b> Adjustable pattern <b>1</b> Special	<b>T</b> T-bar mounted <b>X</b> Threadline mounting 8mm drop face <b>F</b> Threadline mounting 16mm drop face <b>R</b> Recessed mounting <b>C</b> Circular <b>1</b> Special	<b>O</b> External Swirl <b>S</b> Internal Swirl <b>D</b> 1 way <b>C</b> 2 way <b>X</b> Extract <b>1</b> Special	<b>O</b> None <b>C</b> Central screw fixing <b>1</b> Special	<b>F</b> RAL 9010 matt white <b>E</b> RAL 9010 gloss white <b>1</b> Special

## Options and Plenum Order Codes

1. SERIES	2. LINING	3. INSTALLATION METHOD	4. ACCESSORIES	5. ARRANGEMENT	6. SPIGOT TYPE	7. SPIGOT DIAMETER
<b>D</b>	<b>L</b> Lined <b>N</b> Unlined <b>1</b> Special	<b>T</b> Adjustable pattern c/w supports for drop rods <b>1</b> Special	<b>O</b> None <b>A</b> Cord operated monoblade damper <b>B</b> Cord operated monoblade damper (matt black) <b>P</b> Internally painted (matt black) <b>1</b> Special	<b>S</b> Supply <b>E</b> Extract <b>C</b> Circular Supply (please specify type)	<b>R</b> Round — Side entry <b>T</b> Round — Top entry <b>1</b> Special	<b>B</b> 125 <b>C</b> 150 <b>D</b> 200 <b>E</b> 250 <b>F</b> 300 <b>N</b> 315 <b>P</b> 280 <b>R</b> 225 <b>T</b> 175 <b>1</b> Special

Square plenums will be manufactured unless otherwise stated.

## Example of Order Codes

**Diffuser Code:** **DWTTOCF 3660**  
**Plenum Code:** **DLTASRE 3660**

Supply diffuser complete with lined side entry plenum.  
Volume control damper in 250 diameter spigot.  
Overall diffuser size 594mm square with 36 outlet nozzles.  
Diffuser panel powder coated white (RAL 9010) matt.

# PERFORMANCE DATA

Blades	Volume (l/s)	Face Velocity (m/s)	Pressure Drop (Pa)	Throw to 0.5 m/s Velocity (m)	Noise Rating (NR)
9	30	2	14	0.6	12
	40	2.7	25	0.8	18
	50	3.3	38	1	25
	60	4	56	1.2	31
12	40	1.9	13	0.7	13
	50	2.4	19	0.9	21
	60	2.9	27	1	26
	80	3.9	47	1.3	34
16	50	2.1	15	0.7	14
	60	2.5	22	0.9	15
	80	3.4	39	1.1	23
	100	4.2	61	1.3	29
	130	5.5	103	1.4	37
20	65	2.6	10	0.8	10
	75	3	18	0.9	15
	100	3.9	32	1.2	19
	150	5.9	74	1.7	31
24	75	2.8	8	0.8	12
	100	3.7	16	1.1	19
	130	4.8	23	1.4	26
	150	5.6	28	1.6	30
36	80	1.8	6	0.8	16
	100	2.2	9	0.9	17
	130	2.9	15	1.2	21
	150	3.3	20	1.3	25
	180	4	29	1.6	31
48	100	1.1	4	0.9	17
	150	1.7	8	1.3	18
	200	2.2	15	1.7	22
	250	2.8	23	2.1	28
	300	3.3	33	2.5	33

Performance figures are for diffusers only and assume supply air temperature  $-10^{\circ}\text{C}$  to  $+10^{\circ}\text{C}$  relative to room temperature. Throw value is measured horizontally to terminal velocity of 0.5m/s with external pattern (code 0) and ceiling effect. Pressure drop given is static pressure for diffuser only, when used with a plenum box the following corrections are applied – Supply unit  $\text{Ps} \times 2.2$ , NR +5. Multiply throw values by 0.7 for installation without ceiling effect. All NR ratings are based on room absorption of 8db, dampers fully open.



Colman's DWT 2460 model installed at the Royal Albert Dock Redevelopment.



Colman's Circular DWT 2450 model with Circular Plenum.

# PRODUCT RANGES

GRILLES	DIFFUSERS	LOUVRES
Linear Bar	Linear Slot	External
Ceiling	Louvre Face	Circular
Sidewall	Sidewall	Door
Floor	Perforated Face	Screens
Computer Floor	Circular	Penthouse
Cill	Swirl	Sand Louvres
Single & Double Deflection	Ceiling	Roof Louvres
Egg Crate	Sidewall Fixed & Adjustable	
Hinged Core	Jet Flow / Nozzle	
Door Transfer	Repus Displacement Ventilation	
Security and Prison		
Supply and Extract Valves		

## BESPOKE SERVICE

We offer a bespoke design service where standard products do not fit the requirements of the build, we also supply products in special colours and finishes including bronze, brass, gold and chrome to meet Architectural design specifications.

# Mesavent.

Grilles | Diffusers | Louvres | Ductwork | Louvre Windows

Your ventilation solution partner

**COLMAN**  
*Air Distribution*

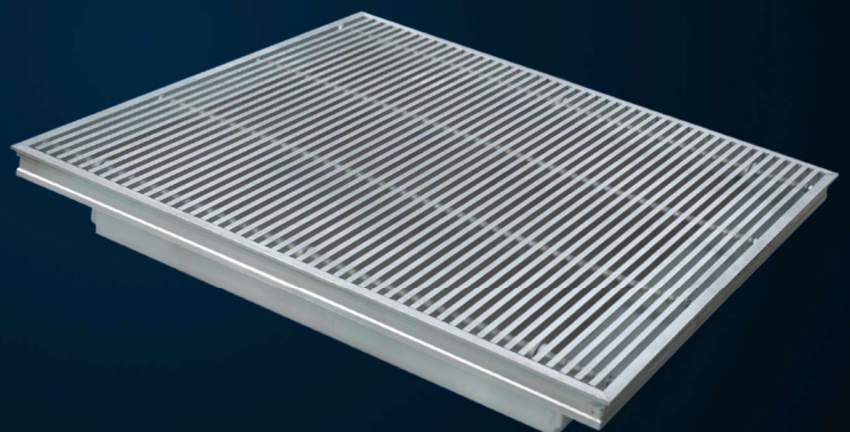

Rydal Road  
Carnforth  
LA5 8LH

www.mesavent.co.uk  
sales@mesavent.co.uk  
01542 900 123